



TORSION-SPRING SECONDARY CLEANER

The highly flexible SRTS Blade cleaner design can self-adjust and maintain blade-to-belt contact via a torsion element, providing effective removal of carryback and maintaining performance by protecting the belt and its splices.

The carryback adheres to the belt, causing serious material accumulation and residue build-up return rollers. Therefore, belt mistracking or belt-edge damage results in unscheduled downtime.

Depending upon the application, 2 materials of blade are available: PU and Tungsten Carbide, which thoroughly scrape conveyor belts clean and eliminate problems with carryback and spillage.

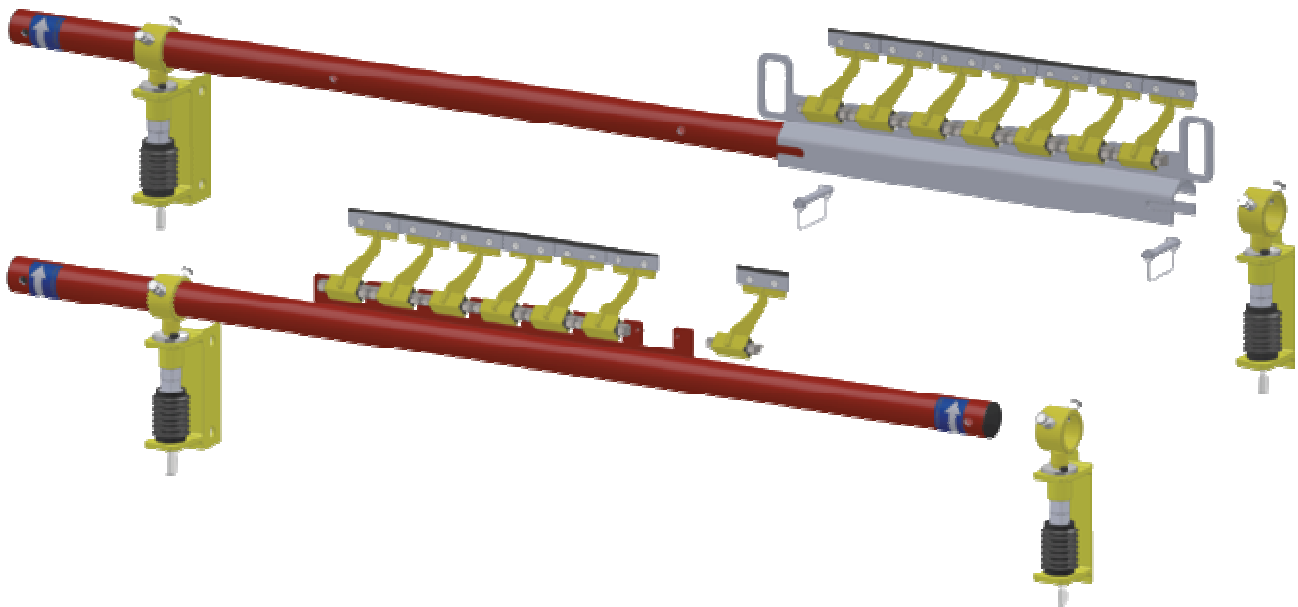

Running Direction →

