

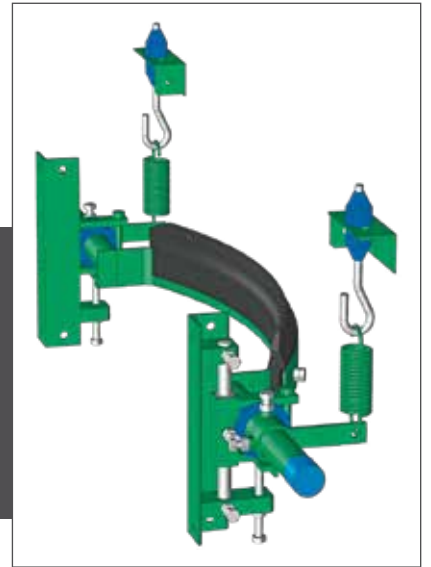

HIGH PERFORMANCE U-TYPE (SECONDARY) SCRAPER FOR BELT CONVEYOR SYSTEMS



The original Belle Banne U-type secondary scraper is unmatched for superior cleaning efficiency - especially in tough applications requiring the removal of wet and sticky material.

The patented U shaped blade conforms to the belt allowing the tungsten carbide tips to scrape stubborn material off the belt while the rubber backing squeeze wet materials.

The dual spring tension system maintains low, uniform blade pressure across the entire belt width. The U shaped blade and offset frame intensify cleaning power in the material carrying center of the belt.

The U-type is unbeatable as the final scraper in a complete cleaning system. Teamed with a Belle Banne primary scraper, the Belle Banne U-type delivers results that are unmatched for cleaning performance and efficiency.

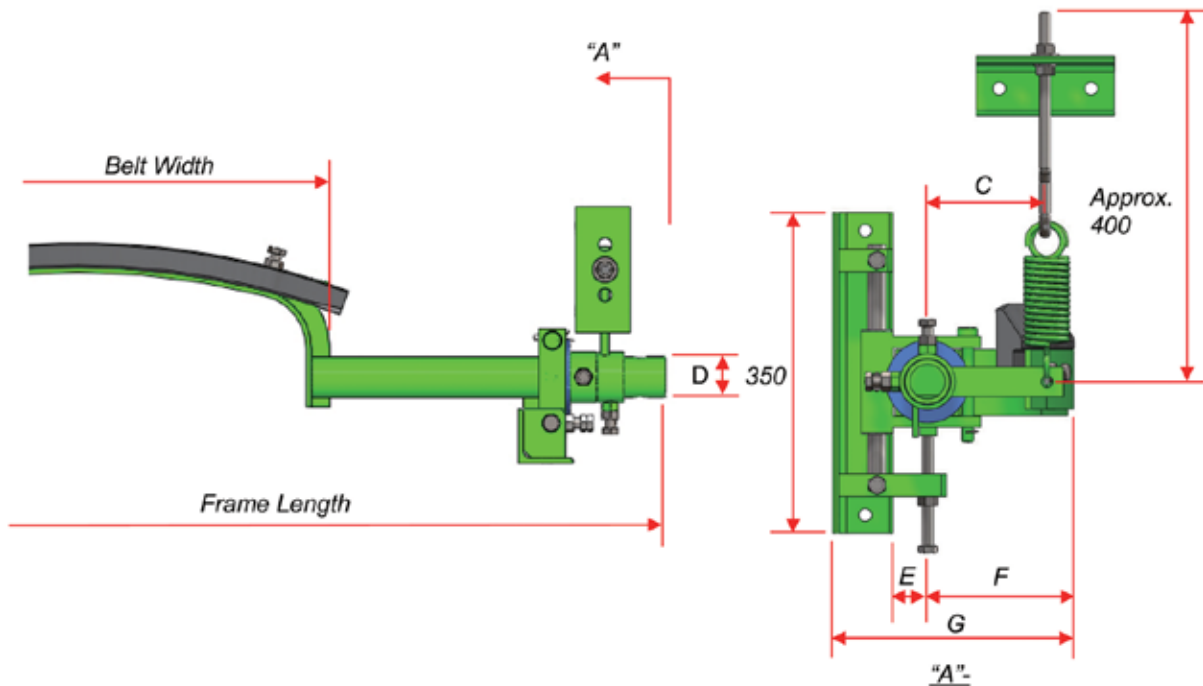

OTHER EQUIPEMENTS

- **STRUCTURES WITH REDUCED CURVE**

U. _{RT} 650 / CR	50 134
U. _{RT} 800 / CR	57 154
U. _{RT} 1000 / CR	63 165
U. _{RT} 1200 / CR	82 188

- **PARTIAL OR TOTAL STAINLESS STEEL**
- **MOUNTS WITH TUBE SUPPORTS**

- **BLADES WITH SPECIAL COATINGS**

- BUTYL for hot products
- NEOPRÈNE for regular products
- NITRILE for products such as hydrocarbons

- **CERAMIC SCRAPING BLADE**

- **CERAMIC BLADE FRAME**

Rubber Blades for Cleaner with metal clips/fastners.

WE PROVIDE TECHNICAL SOLUTIONS RATHER THAN JUST OFFERING PRODUCTS.

FEATURES:

- BELT WIDTH**
Belle Banne U-type scraper is suitable for all belt widths from 450mm - 3000mm
- SINGLE DIRECTION**
The Belle Banne U-type scraper is suitable for unidirectional belt. For reversing conveyor belts, we recommend using the Belle Banne R-type secondary scraper.
- HEAVY DUTY CONSTRUCTION**
Belle Banne scraper frames are the strongest around. All frames are schedule 80 material, ensuring they are fit for tough mining applications.
- STAINLESS STEEL**
Belle Banne scrapers are available in either powder coated mild steel, or 304 stainless steel grade available on request.
- UNIQUE U SHAPE**
The Belle Banne U-type is “unique” in its shape. The U shaped blade maintains maximum pressure in the center of the belt where the majority of the material builds up.
- EASY BLADE REPLACEMENT**
The cartridge blade means that blade removal and replacement can be achieved in just minutes.
- SIMPLE TENSION CHECK**
The spring adjustment system makes for a quick visual check to ensure the Belle Banne U-type is suitably tensioned. Look for a 1 - 2 mm gap in the spring coils.
- ANTI CORROSION**
The U-type scrapers are available in either power coated mild steel or 304 stainless steel with anti corrosion feature.

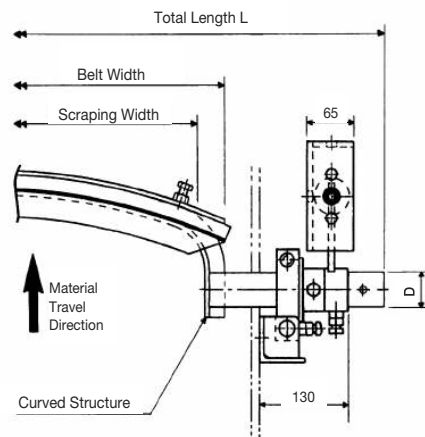
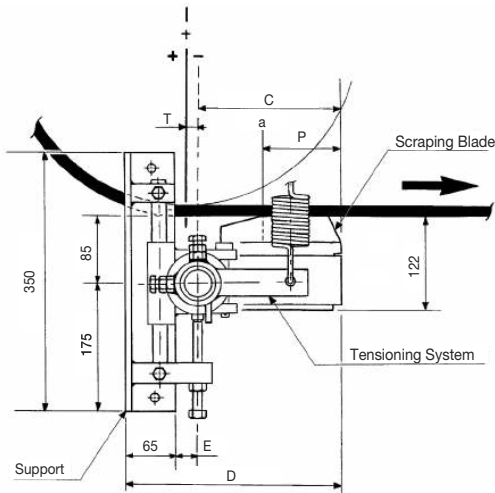

• Consult us for intermediate or higher models

STANDARD MANUFACTURING RANGE

The Cleaner can be mounted with lateral supports to the rear.

MODEL NUMBER	STOCK	BELT WIDTH	SCRAPING WIDTH	LENGTH	D	X	E	F	G	WEIGHT
U.RT 400	*	400mm	400	1200	48,6	55	38	142	245	30 kg
U.RT 500	*	500mm	500	1300	48,6	59	38	147	250	31 kg
U.RT 600	*	600mm	550	1400	48,6	68	38	160	263	32 kg
U.RT 650	*	650mm	600	1450	48,6	73	38	160	263	34 kg
U.RT 800	*	800mm	750	1600	48,6	102	38	188	291	35 kg
U.RT 1000	*	1000mm	850	1800	48,6	97	38	219	322	42 kg
U.RT 1200	*	1200mm	1050	2100	60,5	132	38	242	345	49 kg
U.RT 1400	*	1400mm	1200	2300	60,5	115	38	242	345	55 kg
U.RT 1600	*	1600mm	1400	2500	60,5	134	38	250	353	61 kg
U.RT 1800	*	1800mm	1600	2700	76,3	120	46	250	361	72 kg
U.RT 2000	*	2000mm	1750	3100	76,3	120	46	250	361	81 kg

WE PROVIDE TECHNICAL SOLUTIONS RATHER THAN JUST OFFERING PRODUCTS.